

8" THRU 30" DIA. PIPE = 6"
 33" THRU 60" DIA. PIPE = 8"

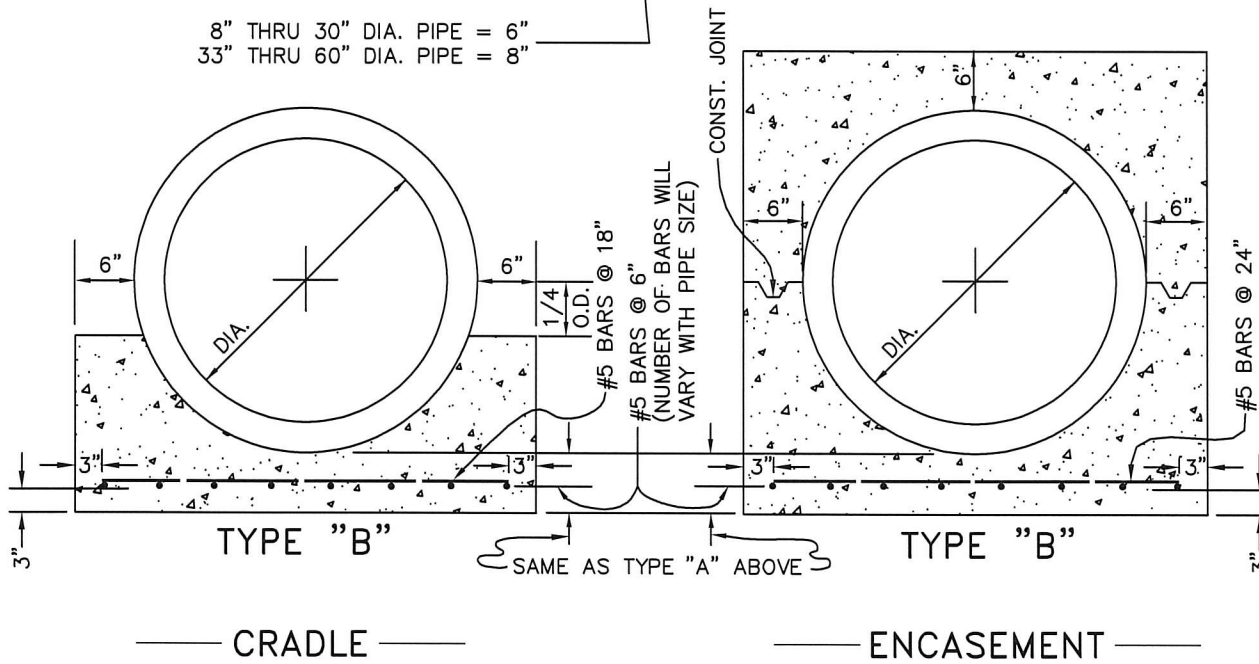

— CRADLE —

— ENCASEMENT —

PIPE SIZE IN.	CRADLE CU. YDS./L.F.	ENCASEMENT CU. YDS./L.F.
8	.0398	.1079
10	.0493	.1266
12	.0619	.1500
15	.0734	.1787
18	.0852	.2085
21	.0922	.2343
24	.1103	.2719
27	.1239	.3058
30	.1381	.3410
33	.1800	.4046
36	.1972	.4443
42	.2335	.5278
48	.2727	.6167
54	.3134	.7111
60	.3570	.8108

QUANTITY TABULATION

THESE QUANTITIES SHALL BE USED TO DETERMINE THE PAY QUANTITY FOR 602.

NOTE:

CONCRETE SHALL BE CLASS "C"

THE
 METROPOLITAN SEWER DISTRICT
 OF
 GREATER CINCINNATI
**STANDARD
 CONC. CRADLE AND
 ENCASEMENT**

NO SCALE

DATE: AUG., 2006

APPROVED:

[Signature]
 SEWERS CHIEF ENGINEER

ACC. NO. 49044