

COVER SECTION B-B FRAME SECTION B-B

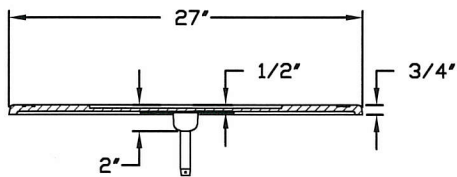

COVER SECTION A-A

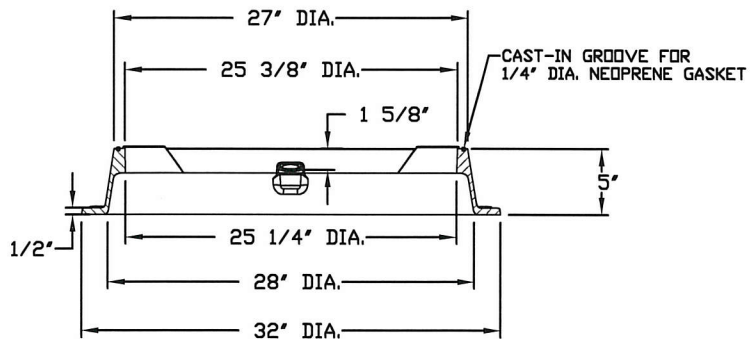

FRAME SECTION A-A

NOTES:

- THIS COVER SHALL ONLY BE USED WHERE SPECIFIED ON THE PLANS.
- NON-TRAFFIC USE ONLY.
- ESTIMATED WEIGHTS:
 - FRAME 85 LBS
 - COVER 60 LBS
 - TOTAL 145 LBS
- FRAME & COVER MATERIAL: CAST GRAY IRON ASTM A48, CLASS 35B
- SPEC. EAST JORDAN 104011R01 OR EQUAL. THERE IS NO GUARANTEE THAT AN EQUAL IS AVAILABLE.

THE
METROPOLITAN SEWER DISTRICT
OF
GREATER CINCINNATI
STANDARD MANHOLE
COVER ON
ELEVATED CONES

NO SCALE DATE: MAY 2008
APPROVED: *Thomas W. Schwens*
INTERIM SEWERS CHIEF ENGINEER